



www.uarx.com

**UARX-Q-CRE-0038-A**  
Rev. 0

May 21, 2021

# UARX Space Transportation Services

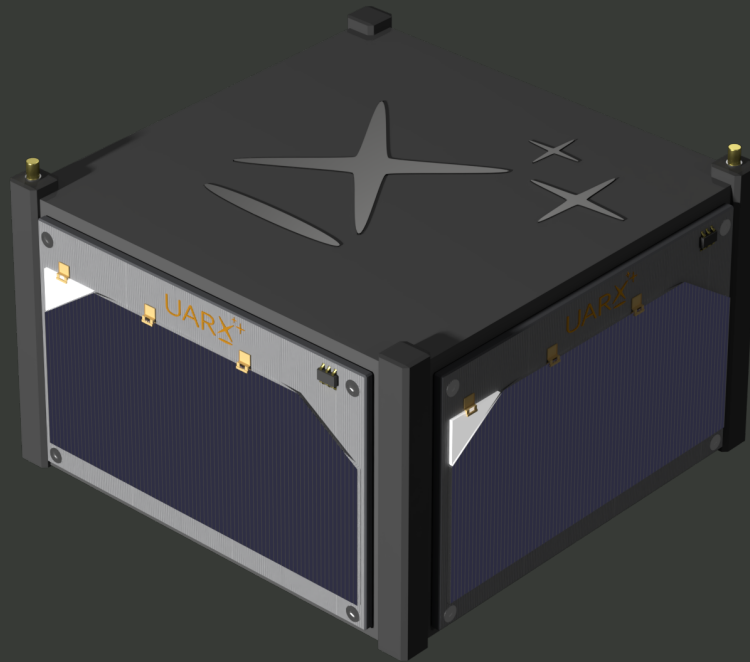

Allocation Quick Specs - 0.5U CubeSat

## Your ride in Space.

# Allocation Quick Specs

## 0.5U CubeSat

Book your ride today!  
rides@uarx.com

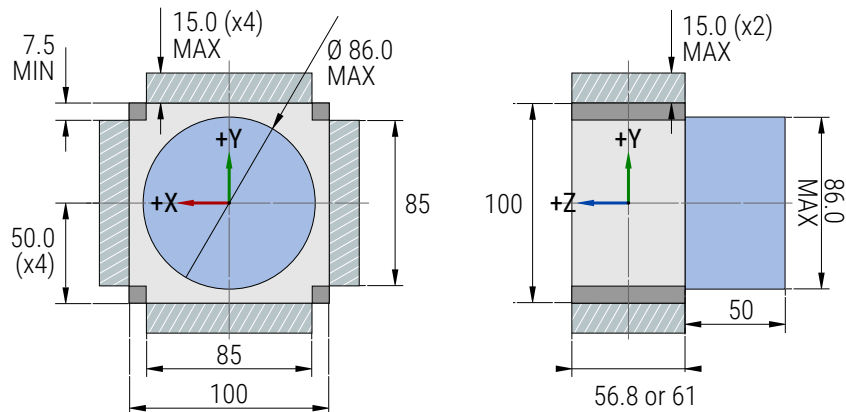

All dimensions are in mm.



RAMI deployers accept two lengths of CubeSats, the standard with 340.5mm, and the XL with 366mm. Customers can take advantage of the extra-room RAMI provides, including the 15mm of protrusions allowance in the dynamic envelope.

Technical Specification	0.5U	0.5U-XL
Maximum payload mass [kg]	1.0	1.0
Number of Tuna Can available	1*	1*
Surface roughness [ $\mu\text{m}$ ]	<1.0	<1.0
Maximum center of gravity deviation <sup>1</sup> in X [mm]	$\pm 20.0$	$\pm 20.0$
Maximum center of gravity deviation <sup>1</sup> in Y [mm]	$\pm 20.0$	$\pm 20.0$
Maximum center of gravity deviation <sup>1</sup> in Z [mm]	$\pm 10.0$	$\pm 10.0$

<sup>1</sup>Deviation is measured from the geometric center of a 0.5U spacecraft.

\*When mounted on the push plate of the deployer. Only available for one spacecraft in the stack.

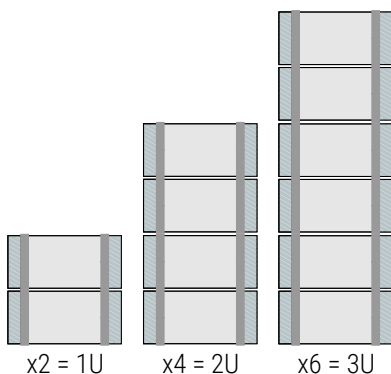

Example of flight configurations for 0.5U CubeSats

CubeSats using a 0.5U form factor may be combined with other spacecraft in the deployer to occupy the assigned bay. The configuration ultimately depends on the manifest and final flight configuration, being possible to combine them with other 0.25U, 0.5U, 1U, 1.5U, or 2U CubeSats.

UARX Space recommends a configuration with enough spacecraft that ensure instant accommodation on a dedicated bay, so the customer will prevent having delays on the assigned spot to fly.